

Assembly and Maintenance Instructions for Flanged Double Bearings

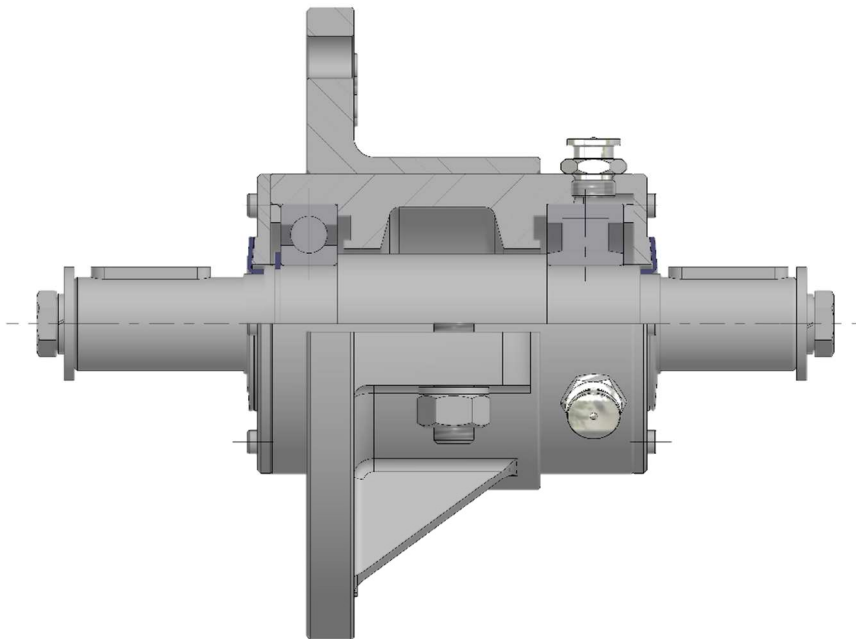

1. General Assembly Regulations

The bearings are delivered as fully assembled units. Roller bearings are pre-lubricated at the factory with a lithium soap grease (special lubricants by agreement, if necessary). The type of grease used is indicated by an adhesive label on the housing. For start-ups or test runs a flanged double bearing 399 T _ N must be relubricated with the appropriate amount of grease (see section 3, Maintenance and Lubrication of Flanged Double Bearings).

When a flanged double bearing is operated in an external location, a weather-proof cover should be used. Corrosive damage to the roller bearings caused by condensation build-up as a result of variations in temperature should be avoided. For this reason, the flanged double bearing must be rotated (approx. 30 revolutions, using the motor or by hand) at least once a week when there are longer downtimes during assembly of the ventilator or entire ventilation system. For low-speed engines, you can fill the entire interior with grease. This prevents the bearing from "breathing". The same applies to bearings which come into contact with corrosive agents.

During assembly, dispatch or transport of the flanged double bearings, particular attention must be paid so that the roller bearings are not damaged. Damages caused by shock and impact should be prevented by providing support for the impeller and belt pulley/coupling.

Our bearings can be used in hot gas blowers. In doing so, observe the following points:

- If the temperature of the conveyer system exceeds 300°C, a special material must be used (for example, material 1.4571 is suitable for a maximum temperature of 850°C due to its high titanium content). In the process, the Young's modulus must be countered with the appropriate dimensioning as it decreases.
- The temperature of the roller bearings must not exceed 120°C for a longer period, as this leads to modifications in the structure of the roller bearing steel, which reduces their service life considerably.

For this reason, the steps required to maintain the maximum allowable temperature must already be taken into account during design of the overall system:

- Sufficient insulation of the rear wall of the fan
- Arrangement of one or more cooling disks
- Possible exterior cooling of the disks
- Instruction to let the fan run out slowly after use

For extreme loads, special greases that cover a greater temperature range (e.g. Urethane E2 from the company Fuchs, with a temperature range of -20 to +200°C) can already be used during assembly (after consultation).

2. Assembly Procedure

- Check the bearing for possible transport damage.
- Remove the protective varnish.
- Check the support trestle to ensure that the surface is even (if the contact surface for the bearing is uneven, put appropriate spaces or wedges below the legs before tightening the foot screws. Otherwise the bearing will be forcibly deformed and its correct functioning can no longer be assured.).
- Position and adjust the bearing on the fan housing.
- Tighten the clamped flange, taking into account the tightening torque for the flange of the flanged double bearing (see table).
- Mount the belt pulley or coupling of the impeller (possibly tension bushings) while using the present tapped holes and thrust washers (do not strike, otherwise the roller bearings will be damaged).
- Ensure axial security of the belt pulley and the impeller by means of washers, lock rings and screws.
- Lubricate the points where the bearing rests according to the lubrication instructions (strict attention must be paid to absolute clean conditions, since foreign matter which gets into the rolling bearings via the lubricant disturbs low noise operation and reduces the service life of the bearings). When using grease lines, make sure that they are also kept clean and that they are filled with grease. Install automatic relubrication devices only after having performed initial lubrication.
- Support the bearing during transport (standstill vibration causes chatter marks).

Tightening Torque for Flanges

Bearing Type / Size	Tightening Torque [Nm]
399 T 15 WD 399 T 20 W 399 T 20 W/ISO 399 T 25 W 399 T 25 W/ISO 399 T 20 N 399 T 25 N 399 T 25 NF	25
399 T 30 W 399 T 30 N 399 T 30 NF 399 T 35 W	35
399 T 40 W 399 T 40 N 399 T 40 NF	40
399 T 50 W 399 T 50 N 399 T 50 NF	50
399 T 60 W 399 T 60 N 399 T 60 NF	60
399 T 75 N	60

3. Maintenance and Lubrication for Flanged Double Bearing

399 T N

For the maintenance and relubrication of the bearings, always observe the recommendations of the bearings' manufacturers.

Relubrication must be performed as long as a sufficient lubrication of the roller bearings is still provided by the existing grease. When relubricating, strict attention must be paid to ensure that lubricants, greasing nipples and grease lines are kept clean, since foreign matter disturbs low noiseoperation and reduces the service life of the bearings.

Unfavourable environmental conditions (such as a lot of dust and moisture, splashing water, aggressive agents, etc.) require - in addition to a good seal (constructive design of the manufacturer) - a regular grease supply. The lubricant increases the effectiveness of the seals by penetrating the gaps between the seals and keeping out foreign matter.

When using relubrication devices, it is critical that you first manually apply the required amount of grease for the start-up or test run before using the relubrication device.

If special lubricants were not stipulated, the bearings are pre-lubricated with a lithium soap grease (temperature range: -35°C to $+140^{\circ}\text{C}$) during production. Lithium soap greases can be mixed with one another, which means that our bearings can be relubricated with all lithium soap greases, as long as they correspond to the temperature range.

The maximum bearing temperature (measured on the roller bearing) must not exceed 120°C . In addition to the above-mentioned negative effects (structural changes), excessive temperatures cause the grease to bleed.

If the temperature of the bearing exceeds the above mentioned degree (e.g. an emergency stop of the system), at least the lubricating capacity must be immediately restored. To do so, the roller bearings must be rinsed with fresh grease (insert double the initial fill quantity while rotating the bearing), whereby the existing temperature-damaged grease is discharged into the interior of the bearing.

The relubrication intervals depend on the operating speed and the bore diameter of the roller bearing and can be derived from the following diagram. The determined lubrication times apply to bearings in horizontal use at a maximum temperature of 70°C. Since lubricants age more rapidly at higher temperatures, the lubrication interval must be reduced by 50% for each increase in temperature of 15°C.

Lubrication intervals in excess of 30,000 operating hours are not recommended. The lubrication interval should also be reduced by 50% if the bearing is operated vertically.

After determination of the relubrication intervals, the quantity of grease to be relubricated must be calculated as follows:

$$G_{\text{period}} = 0.005 \times D \times B$$

G_{period} [g] Periodic supply of grease

D [mm] Outer diameter of bearing

B [mm] Total width of bearing

Diagram for Determining Relubrication Intervals

Operating hours t_f [h]

d = Roller bearing inner diameter [mm]

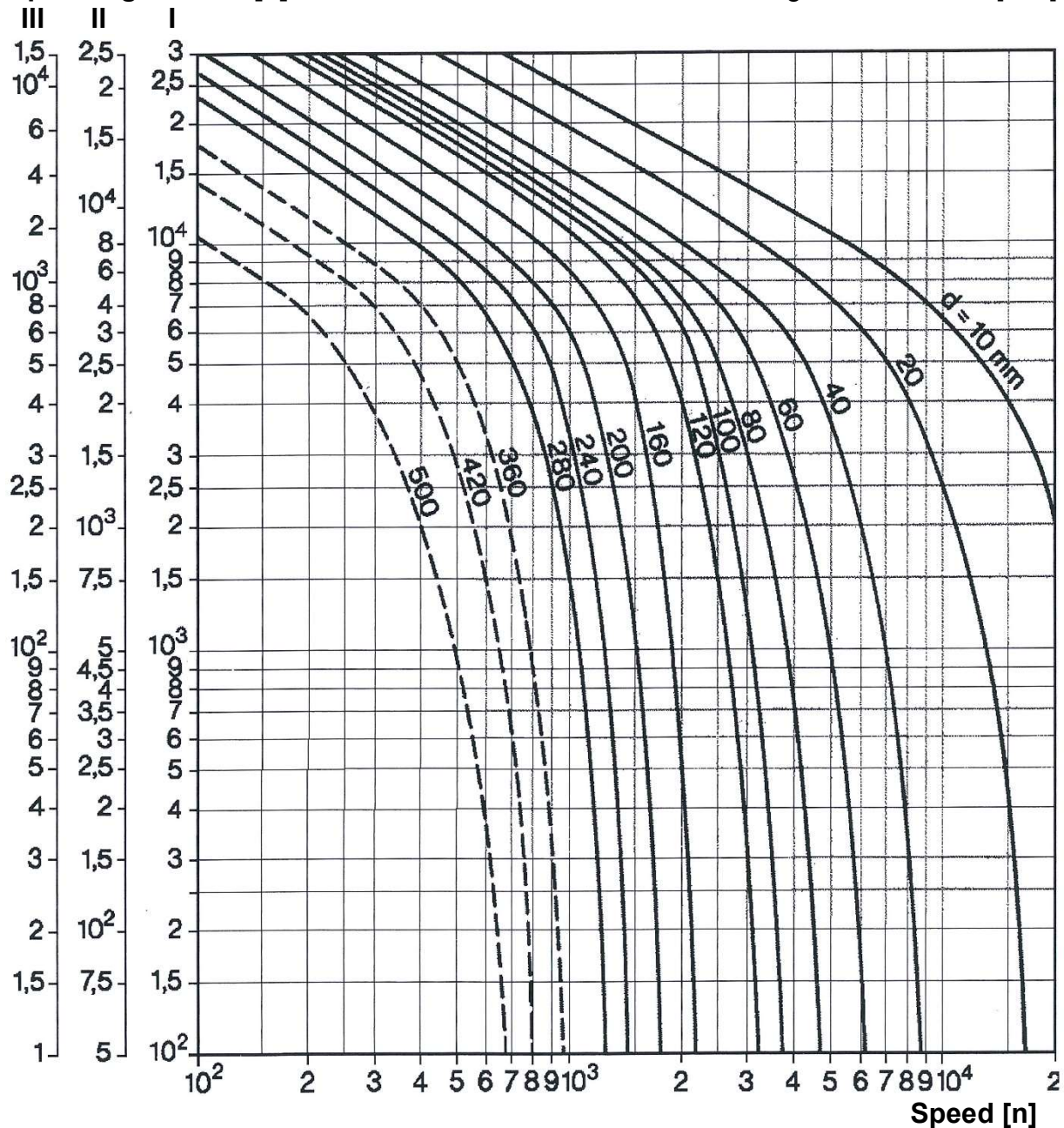

Scale I: Radial ball bearings; **Scale II:** Cylinder roller bearings; **Scale III:** Spherical roller bearings

Reduce the determined lubrication interval t_f [h] by 50% for:

- Vertical installation
- Each increase in temperature of 15°C for temperatures above 70°C